

The Original Ezy Reveal – Now Available In Any Size

Trying to create that clean line architrave free window or door trim, and can't find the exact size? Studco has a solution.

Three extra standard sizes to the popular Ezy Reveal range have been added bringing the total to 17 profiles, in stock at standard 3000mm and 3600mm lengths. Refer to the chart below showing the current standard stock sizes. Still can't find a size to suit? Ezy Reveal is also now available made to order in any width ranging from 37mm thru to 145mm in 1mm increments. Call Studco sales team today to discuss your requirements. ■

EZY reveal

EXPANDED RANGE

- 17 sizes now available -

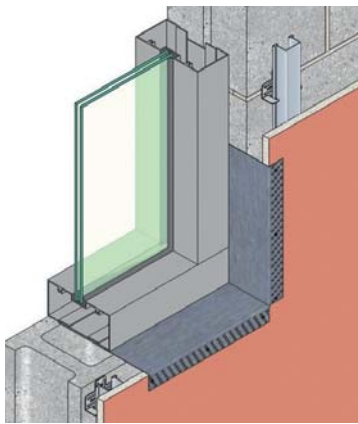

EZYreveal is ideally suited to commercial window & shopfront applications

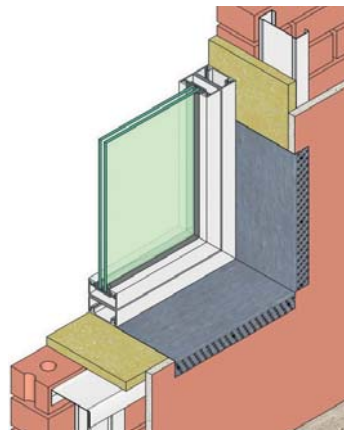

For domestic windows, slide the EZY reveal behind the window for a seamless finish

CODE	DESCRIPTION	LENGTH
RA20	EZYreveal 20mm x 0.8mm	3.0m/3.6m
RA25	EZYreveal 25mm x 0.8mm	3.0m/3.6m
RA30	EZYreveal 30mm x 0.8mm	3.0m/3.6m
RA35	EZYreveal 35mm x 0.8mm	3.0m/3.6m
RA40	EZYreveal 40mm x 0.8mm	3.0m/3.6m
RA45	EZYreveal 45mm x 0.8mm	3.0m/3.6m
RA50	EZYreveal 50mm x 0.8mm	3.0m/3.6m
RA60	EZYreveal 60mm x 0.8mm	3.0m/3.6m
RA65	EZYreveal 65mm x 0.8mm	3.0m/3.6m
RA75	EZYreveal 75mm x 0.8mm	3.0m/3.6m
RA80	EZYreveal 80mm x 0.8mm	3.0m/3.6m
RA90	EZYreveal 90mm x 0.8mm	3.0m/3.6m
RA100	EZYreveal 100mm x 0.8mm	3.0m/3.6m
RA110	EZYreveal 110mm x 0.8mm	3.0m/3.6m
RA120	EZYreveal 120mm x 0.8mm	3.0m/3.6m
RA135	EZYreveal 135mm x 0.8mm	3.0m/3.6m
RA150	EZYreveal 150mm x 0.8mm	3.0m/3.6m

STUDCO GREENSMART

Studco's Commitment To Environmental Responsibility

After a rigorous auditing process Studco has now been granted ISO 14001 Environmental Management System (EMS) Certification. The management team at Studco have long held the view that caring for the environment is a corporate responsibility. In fact, responsibility of and caring for the environment in which we live is a Studco hallmark which is promoted at every level of our business. Our commitment to sensible environmental responsibility and corporate accountability is evident in our ongoing certification to the internationally recognised benchmark standard ISO14001 :2004 environmental management system. Studco seeks to lead the way in environmentally responsible business practises and we believe in great investment for developing products that save energy and protect the environment. Look out for the next edition of the Studco Update to find out how the Studco EMS system can add value to your next project. ■

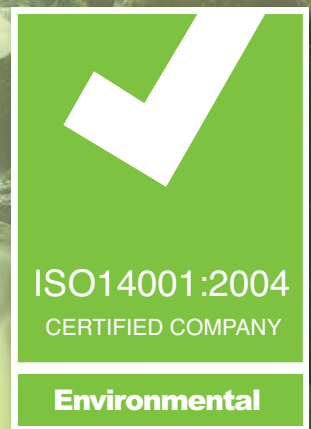

Australia's
most popular
external angle
just got better!



TRIM90[®]
PLASTERBOARD BEADS

- ✓ **Optimum Nib Profile**
MINIMUM COMPOUND, SMOOTHER FINISH
- ✓ **Increased Steel Gauge**
SHARPER, STRAIGHTER LINES
- ✓ **30mm Perforated Legs**
WITH MAXIMUM COMPOUND ADHESION
- ✓ **Quality Galvanised Steel**
LONGER LASTING DURABILITY
- ✓ **Packaged In Boxes**
PROTECTION FOR YOUR CONVENIENCE

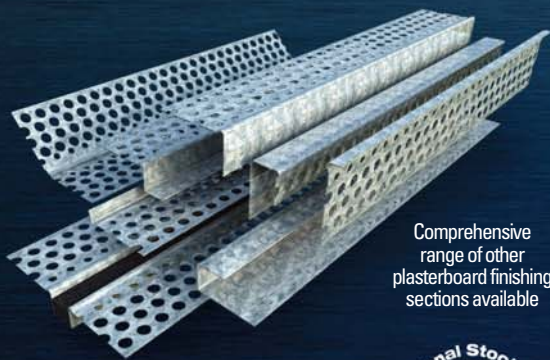

Comprehensive
range of other
plasterboard finishing
sections available



Available at a store near you



1800 STUDCO
WWW.STUDCOSYSTEMS.COM.AU

Floor To Ceiling Sound Isolation For Low Rise Dwellings



Resilmount M96R resilient
mount bracket

A common challenge for designers of low rise dwellings is to provide an effective acoustic solution to limit the transfer of sound between levels, with the prime goal being that the occupants on the floor below hear less of what goes on above them!

The Resilmount M96R resilient mount bracket is designed to reduce the loss of amenity in low rise apartments, multi level homes and similar buildings by isolating airborne sound transmission at the floor/ceiling intersection. It is suitable for fixing to steel or timber floor joists and is used in conjunction with Studco furring channel profiles. Made with Resilmount's patented sound-cell technology, the Resilmount M96R resilient mount bracket is code compliant and is recommended by Australia's leading acoustic engineers.

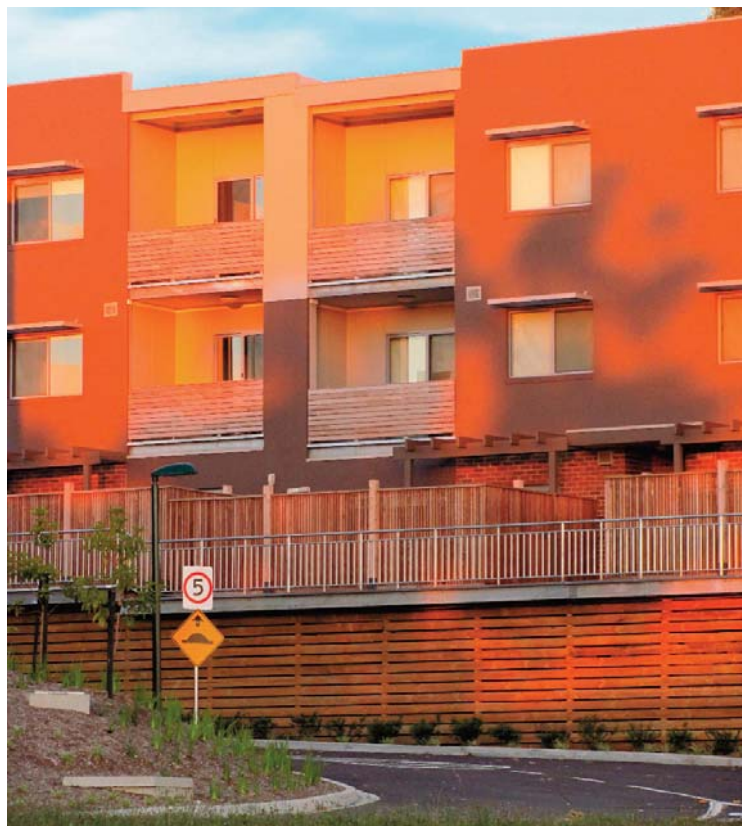

This new government-funded housing estate uses the Resilmount M96R to provide maximum comfort to the occupants.

NEW

Energy Efficient Wall System From Studco

SLIMWALL
ENERGY EFFICIENT WALL SYSTEM

Studco continues to lead the way in innovative building products with the release of Slimwall, a new energy efficient wall system that is code compliant to NCC 2011 Section J (BCA 2011) Energy Efficiency criteria, making it easier than ever to score Green Star points in new building projects.

This brilliant innovation offers a substantially improved method for battening the interior surfaces of external walls by enabling a larger wall cavity to be created that minimises thermal transfer and maximises energy efficiency. The Studco Slimwall system is fully adjustable so it can be used on uneven surfaces, and it's suitable for use with almost any wall structure, including precast concrete panels, masonry walls, timber framing and lightweight steel stud systems.

The new Slimwall M163 bracket is the main component of the Slimwall system and is available in two sizes for use with various width insulation products...

M163-6 Studco Slimwall bracket - suitable for wall cavities 69-92mm

M163-8 Studco Slimwall bracket - suitable for wall cavities 85-108mm

Once the M163 brackets are fixed to external wall using shot pins or masonry anchors, the Studco Slimceiling M355 channels are inserted into the brackets and screwed to the brackets, achieving a secure and permanent fixing which can support a wide variety of lining board types and weights.

The system works with most insulation types including building blankets, batts, expanded polystyrene (EPS), closed-cell foams and encapsulated air polymers. The void spacer on the M163 bracket ensures the insulation material remains at a fixed distance from the external wall surface, as required by the building code. The Studco Slimwall system has been fully engineered for structural integrity, it is endorsed by major Australian insulation manufacturers and it is 100% Australia made.

So whether you're chasing 6 Star Green Star on your next project or you just need a fast, flexible and fully code compliant wall system, choose the unique, new Studco Slimwall.

The new energy efficient Studco Slimwall system was launched in conjunction with the World Green Building Week 2011. Availability is subject to confirmation at this stage.

For architectural specifications, or to order, or for more information, please call 1800 STUDCO or email us. ■

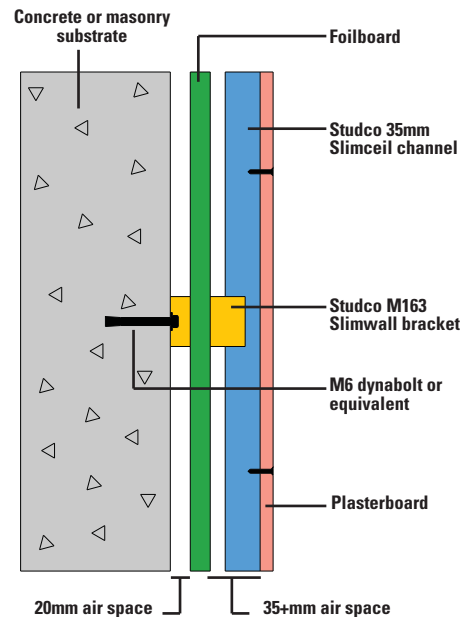

Studco Slimwall system used with foilboard insulation to achieve R1.8 rating.

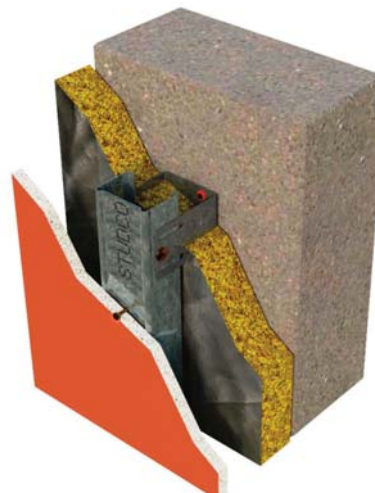

Studco Slimwall system used with CSR Bradford foil-faced builders blankets to achieve R2.8 rating.

TECH TIPS

How To Brace A Steel Stud Wall

Occasionally, walls need to be diagonally braced between the steel studs and the structure, most commonly above the ceiling height. Typically, steel stud offcuts are used for the bracing.

The bracing studs are screwed to the wall studs with a number of structural tek screws. Typically, connections often require three or four tek screws (self drill screws) per connection. At the connection with the structure, various fixing methods have been employed by site contractors but not all methods comply with the minimum strength requirements for this type of connection.

The correct method for fixing the bracing stud to the structure is to use an engineered metal bracket that is capable of handling extreme loads, to make a firm and secure connection. However, the angle of the bracing stud and the size of the bracket often limits the number of screws that can be applied to the joint, thus greatly limiting the effective strength of the connection.

Enter the optimum solution: *the new Studco M104 connector.*

The Studco M104 connector is designed for use in wall bracing applications and it boasts a large variety of holes sizes and locations to ensure that the bracing stud intersects with a minimum of four location holes on the connector bracket at all times. This also enables installation of bracing studs between 15° and 60° from the vertical plane.

The connection bracket can be fixed to the structure using a dynabolt (for concrete structures) or a bolt and nut combination (for steel structures) or structural screws (for timber structures).

Typical applications for wall bracing in steel stud walls include

- External steel stud walls, subject to high wind pressures
- High internal walls that require additional support
- Internal steel stud walls with heavy lining or objects fixed to one side
- Suspended bulkheads and ceiling features
- Internal infill walls over aluminium partitions or shopfronts

The Studco M104 connector bracket is made in Australia from BlueScope galvanised steel and it's engineered to perform in all internal and external wall bracing applications.



The versatile M104 connector bracket from Studco.

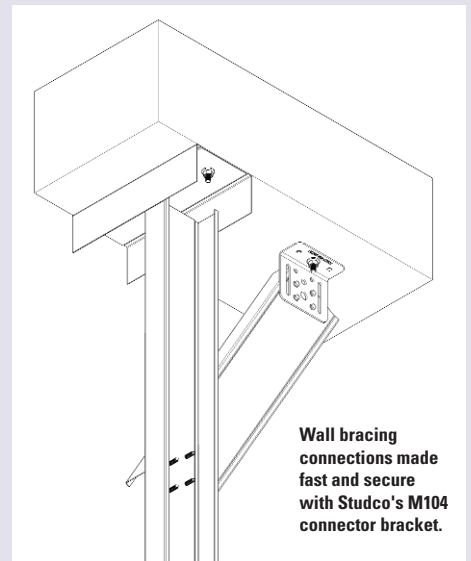

Wall bracing connections made fast and secure with Studco's M104 connector bracket.

DID YOU KNOW? 

The M104 connector bracket has many other uses...

- Secure fixing of jamb studs in openings
- Connect lightweight lintels & sills to jamb studs
- Deflection cleat for external wall studs and
- Connect Trusses to walls.

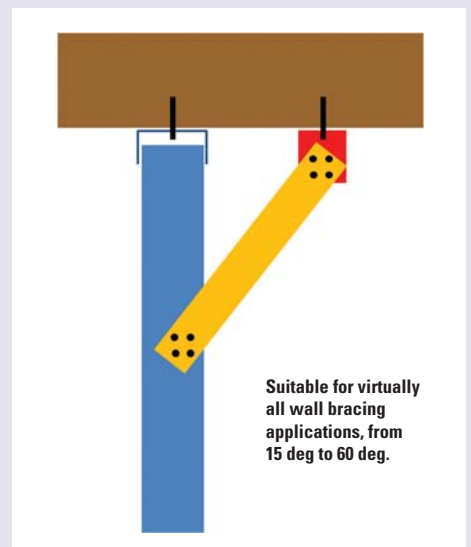

Suitable for virtually all wall bracing applications, from 15 deg to 60 deg.



MORE INFORMATION?

For engineering assistance, email techadvice@studcosystems.com.au

© Copyright 2011 Studco Building Systems Pty Ltd. All rights reserved. Information is correct at the time of publication but no responsibility or liability accepted. Refer to Studco terms & conditions. Errors & omissions excepted. This newsletter is not to be reproduced in any form without written permission from Studco Building Systems. Information printed in this document or communicated by the manufacturers, distributors or any agent is subject to change without notice. Studco Building Systems will accept no responsibility for the accuracy of information supplied. The Studco logo, Ezy-Jamb logo and Resilmount logo are registered trademarks of Studco Building Systems Pty Ltd. The Trim90 logo and HEDA logo are trademarks of Studco Building Systems Pty Ltd.